

# GNY AIRCRAFT GROUND SERVICE PIT TESTING OF PITS FOR WATER RESISTANCE

FOR AIRPORT APRON AND HANGER MAINTENANCE FACILITIES

GNY offers a variety of water-resistant covers for the accompanying pits. The dual water-resistant seal is put on both the inner and the outer covers.

Testing for this water resistance is done in-house at GNY.

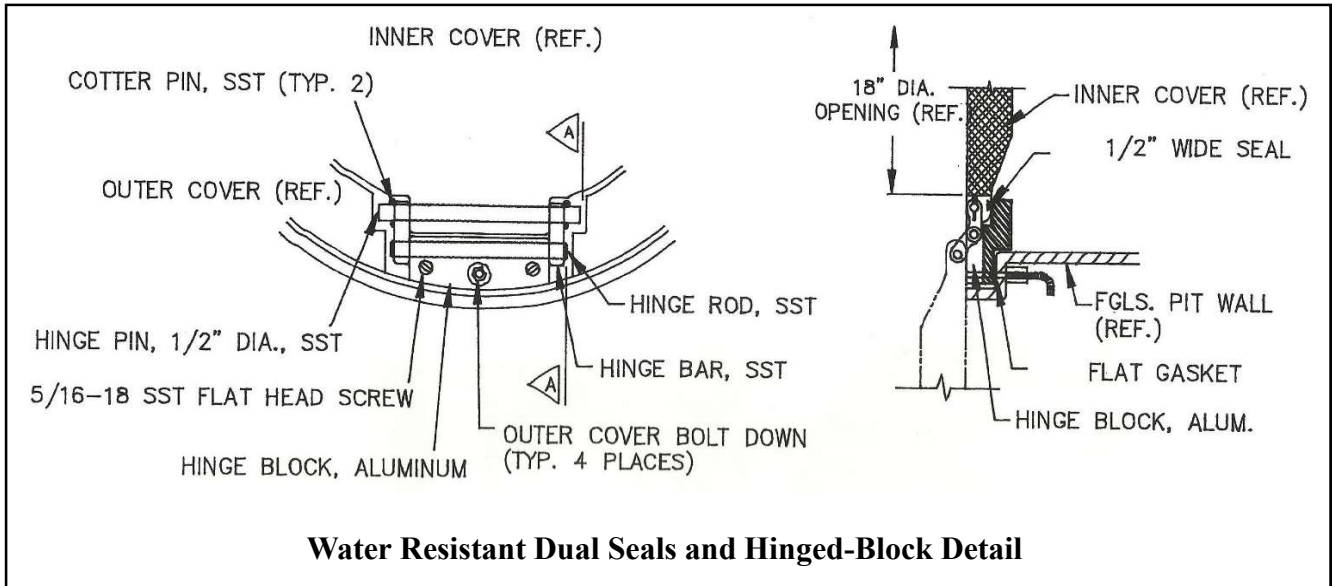

**Testing: Model 1463WR- Water Resistant Assy. Under Water Test:**

**2" of water on Top Cover for 30 minutes**

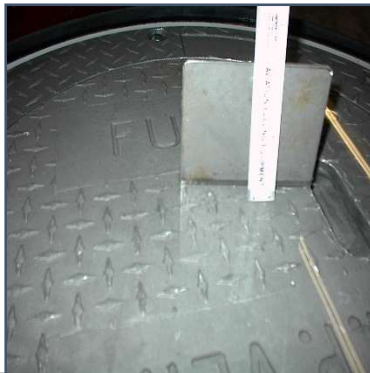

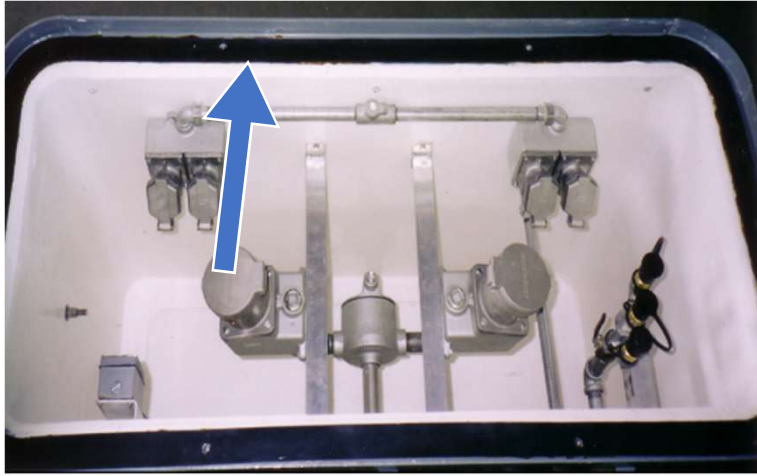

Water Resistant Flat Gasket installed on all four sides of the outer cover (Model 6000WR)



O-ring Gasket on Inner Covers for full 360° (Model 6000WR)



Water-Resistant Hinge Seal Gasket Installed between Rear Hinged Fixed Covers & Main Counter-Weight Opening Cover (Model 8000WR)



Water-Resistant O-Ring Seal Gasket Installed on Main Counter-Weight Opening Cover (Model 8000WR)